



Wissekerke

Techniek B.V.

Nijverheidsweg 20 3251 LP Stellendam tel.: (0)187 - 490 290
Postbus 7 3253 ZG Ouddorp fax: (0)187 - 490 299
E-mail: info@wissekerke.nl www.wissekerke.nl

Authorized dealer

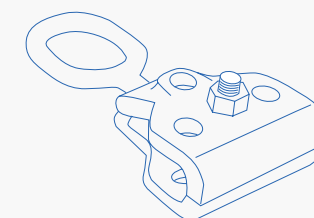

UTENSILI PROFESSIONALI

PROFESSIONAL TOOLS
OUTILS PROFESSIONNELS
KAROSSERIE-RICHTWERKZEUG

Made in Italy 

ART. 251
PINZA AUTOBLOCCANTE
AUTOMATICA

Fast automatic clamp
Pince autobloquante automatique
Zugklemme, selbstspannend (automatisch)

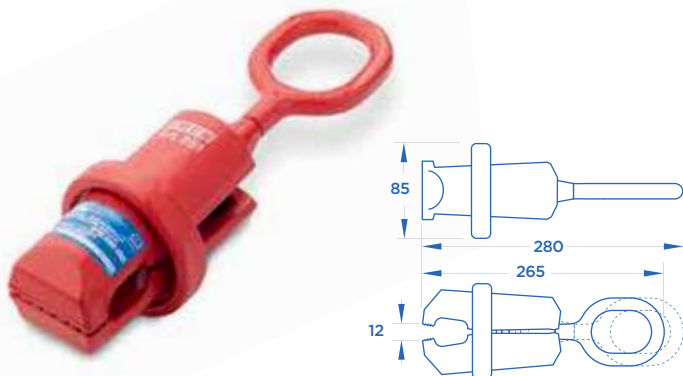

ART. 276
PINZA AUTOBLOCCANTE
AUTOMATICA A TENAGLIA

Fast selflocking scissor clamp
Pince à tenailles autobloquante automatique
Zangenzugklemme, selbstspannend



ART. 277
PINZA AUTOBLOCCANTE A
TIRAGGIO PLURIDIREZIONALE

Selflocking swivel clamp
Pince autobloquante pluridirectionnelle
Zugklemme, selbstspannend, mit beweglicher Zugöse

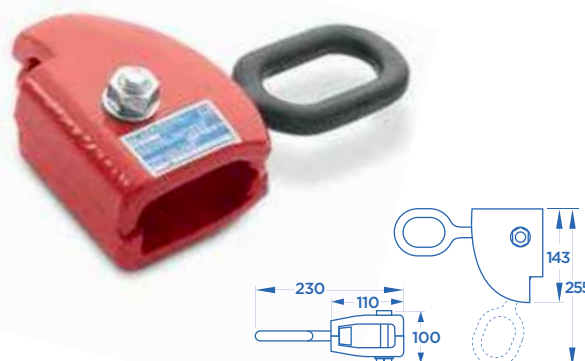

ART. 277/A
MINI PINZA AUTOBLOCCANTE
A TIRAGGIO PLURIDIREZIONALE

Mini selflocking swivel clamp
Mini pince autobloquante à traction pluridirectionnelle
Kleine Zugklemme, selbstspannend



ART. 277/B
MORSETTO A DOPPIO INCAVO COMPLETO
DI AGGANCIAMENTO ACCORCIA CATENA
PER TIRO PARAFANGHI

Clamp with double cavity complete with coupling-shortening chain for pulling mudguards
Pince à double encoche avec d'accroche chaîne pour tirer les gardes-boues
Kotflügel-Zugklemme, mit zwei Ausparungen zum Einhängen von Kette



ART. 278
PIASTRA PLURIFORATA PER
TRAZIONE TELAIO

Multi-drilled pull plate
Barre de traction à perforations
Zugbügel mit verschiedenen Befestigungslöchern

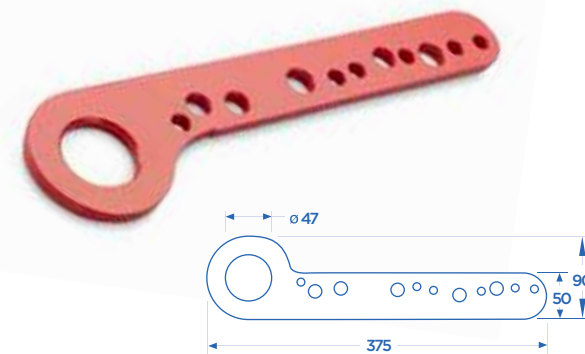

ART. 279
MORSETTO AUTOSERRANTE
DI TRAZIONE (MM. 100)

Selflocking clamp width (100 mm.)
Pince de traction (100 mm.)
Zugklemme, selbstspannend (100 mm.)

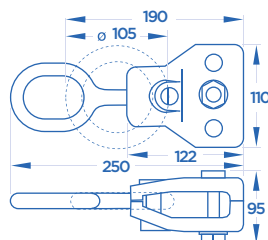

ART. 280
MORSETTO AUTOSERRANTE
PER AGGOCCIOLATOI (MM. 70)

Selflocking clamp width (70 mm.)
Pince de traction (70 mm.)
Zugklemme, selbstspannend (70 mm.)
für Regenrinne

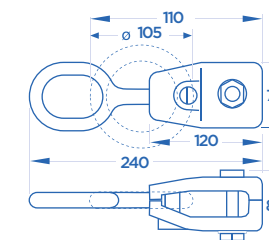

ART. 281
MORSETTO AUTOSERRANTE
DI TRAZIONE (MM. 45)

Selflocking clamp width (45 mm.)
Pince de traction (45 mm.)
Zugklemme, selbstspannend (45 mm.)

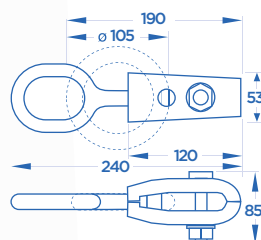

ART. 282
MORSETTO AUTOSERRANTE
DI TRAZIONE A ANGOLO RETTO

Selflocking right angle clamp
Pince de traction à angle droit
Zugklemme, selbstspannend,
mit zwei Zugmöglichkeiten

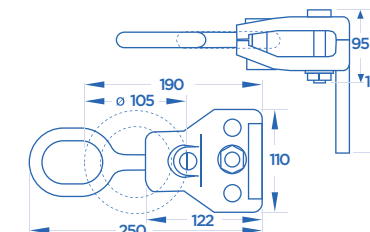

ART. 285
BRACCIO A GANCIO CON TRE ATTACCHI
ADATTABILI, DI CUI UNO FILETTATO

Arm with 3 adjustable couplings of which one is threaded
 Crampon avec trois attaches dont une fileté
 Zugbügel mit drei anpaßbaren Befestigungsstücken

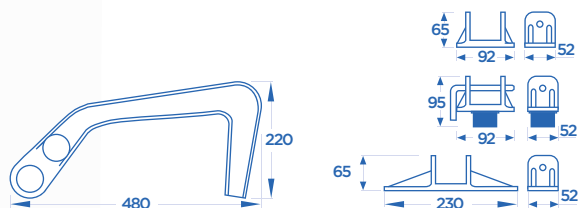

ART. 286
STAFFA GUIDA CATENA PER
DOPPIA TRAZIONE

Chain yoke for double pull
 Guide chaîne pour traction double
 Kettenumlenker

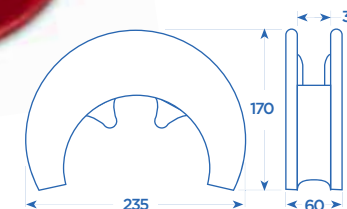

ART. 283
STAFFA DI TRAZIONE
PER MORSETTI AUTOSERRANTI

Pull yoke for selflocking clamps
 Axe de traction pour pinces autoserrantes
 Zugbügel für selbstspannende Zugklemmen

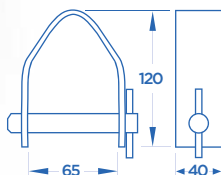

ART. 285/A
MINI BRACCIO A GANCIO, CON ATTACCO
ADATTABILE E PROLUNGA A LEVA

Mini arm with adjustable coupling and lever extension
 Mini bras à crochet avec attache adaptable et rallonge à levier
 Kleiner Zugarm mit Steckkupplung und Hebelverlängerung

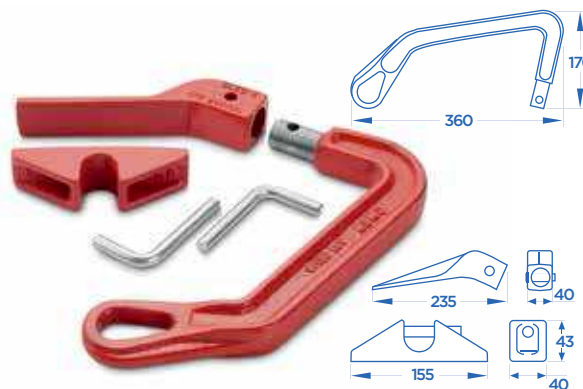

ART. 287
ATTREZZO UNIVERSALE DI TRAZIONE AD
ANCORAGGIO PER LE TESTE DI FISSAGGIO
DELLE SOSPENSIONI MAC PHERSON

Universal straightener pulling tool for fixing heads
 of Mac Pherson suspensions
 Elément universel de traction à ancrage pour les têtes
 de fixation de suspensions Mac Pherson
 Universal Aufspannvorrichtung für Mac Pherson
 Federbeinaufnahmen

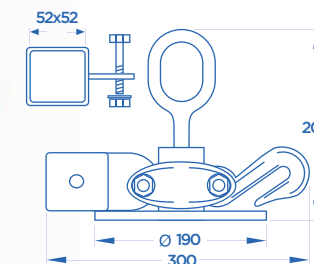

ART. 393 MORSETTO A DOPPIO BRACCIO MULTIUSO

Multipurpose double arm clamp
Étau à double bras multifonctionnel
Zugklemme mit vielseitig verwendbarem Doppelarm

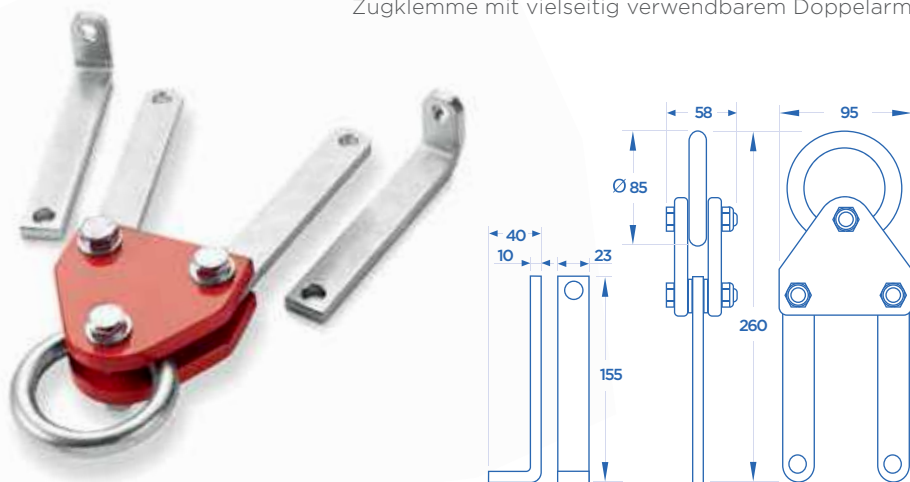

ART. 295/SP MORSETTO AUTOBLOCCANTE AUTOMATICO CON GANASCE RIPORTATE (MM. 60)

Automatic selflocking clamp with inserted jaws (mm. 60)
Étau autobloquant automatique avec mâchoires (mm. 60)
Automatisch selbstspannende Zugklemme mit auswechselbaren Backen (60 mm.)



ART. 296/SP MORSETTO AUTOBLOCCANTE AUTOMATICO CON GANASCE RIPORTATE (MM. 100)

Automatic selflocking clamp with inserted jaws (mm. 100)
Étau autobloquant automatique avec mâchoires (mm. 100)
Automatisch selbstspannende Zugklemme mit
auswechselbaren Backen (100 mm.)



ART. 297 MORSETTO PICCOLO

Little clamp
Petit étau
Kleine Klemme (mit Ring)



**ART. 299/A
MORSETTO A TENAGLIA**

Pincer clamp
Étau à tenaille
Zangenklemme

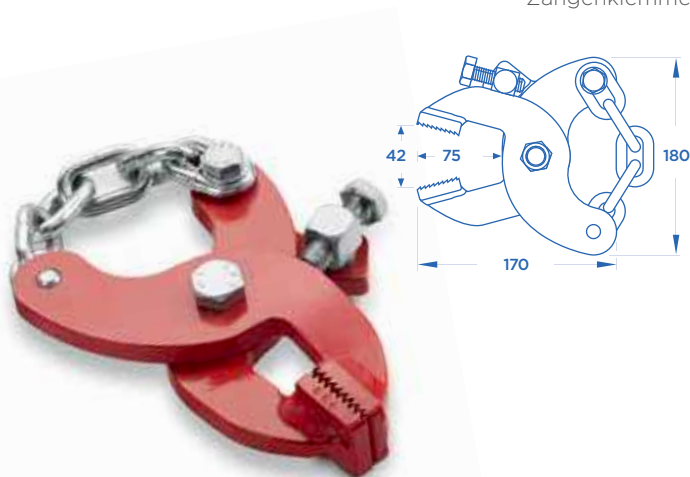

**ART. 299/C
MORSETTO A TENAGLIA**

Pincer clamp
Étau à tenaille
Zangenklemme



**ART. 299/E
MORSETTO A TENAGLIA
CON BRACCETTO LATERALE**

Pincer clamp with little lateral arm
Étau à tenaille avec petit bras latéral
Zangenklemme mit kleinen seitlichen Armen



**ART. 299/B
MORSETTO
A TENAGLIA**

Pincer clamp
Étau à tenaille
Zangenklemme



**ART. 299/D
MORSETTO
A TENAGLIA**

Pincer clamp
Étau à tenaille
Zangenklemme



**ART. 299/H
MORSETTO
A TENAGLIA**

Pincer clamp
Étau à tenaille
Zangenklemme



**ART. 299/F
CATENA AD ELEVATA
RESISTENZA COMPLETA
DI GANCI DA IMPIEGARE CON
IL MORSETTO ART. 299/E**

High resistance chain complete with hooks to be used with clamp Art. 299/E

Chaîne haute résistance avec crochets.
A utiliser avec l'étau Art. 299/E

Widerstandsfähige Kette,
Komplett mit Haken;
für Art. 299/E

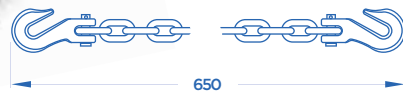

**ART. 299/L
MORSETTO
A TENAGLIA**

Pincer clamp
Étau à tenaille
Zangenklemme

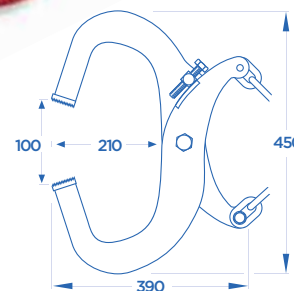

**ART. 299/M
MORSETTO
A TENAGLIA**

Pincer clamp
Étau à tenaille
Zangenklemme

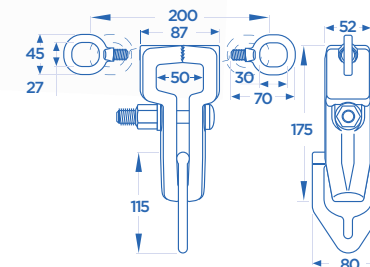

**ART. 299/I
MORSETTO
A TENAGLIA**

Pincer clamp
Étau à tenaille
Zangenklemme

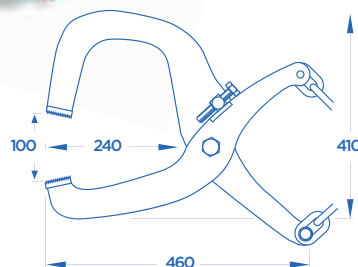

**ART. 299/N
MORSETTO
A TENAGLIA**

Pincer clamp
Étau à tenaille
Zangenklemme

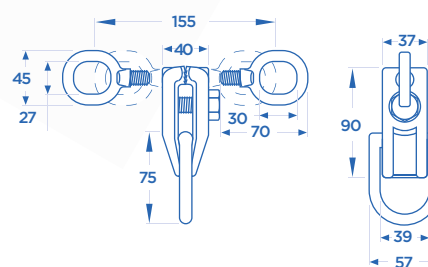

**ART. 299/O
STAFFATORE PER
CINGHIE E CATENE**

Molder for belts and chains
Guide pour chaînes et sangles
à double traction
Bügel für Riemen und Ketten

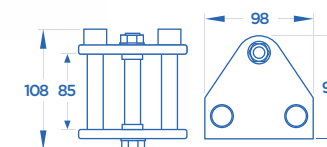

BELT KIT



ART.

mm

RIF. A	800
RIF. B	1200
RIF. C	1800
RIF. D	1000



Cinghie in poliestere ad elevata resistenza. Particolarmente indicate per operazioni di tiro in carrozzeria, ben si adattano a molteplici e svariati impieghi. L'estrema flessibilità, duttilità e leggerezza, unite alla elevata capacità ed alla sicurezza d'impiego, ne fanno un indispensabile strumento di lavoro. Le asole terminali rinforzate ben si accoppiano con ganci e catene di nostra produzione.

High resistance belts in polyester. Particularly suited for pulling operations in car's body-work, and adapted for multiple and various uses. The extreme flexibility and lightness together with the high capacity and use safety, make it an indispensable work instrument. The straightened terminal holes fit well with hooks and chains produced by us.

Courroie en polyester à haute résistance. Par ses emplois variés et multiples, elle est particulièrement indiquée dans les opérations de tirage en carrosserie. Son extrême flexibilité, sa légèreté s'unissent à une capacité de tension élevée et à une sécurité d'emploi pour en faire un indispensable instrument de travail. Les boutonnières terminales renforcées s'adaptent aux crochets et chaînes de notre production.

Hochwiderstandsfähige Gurte aus Polyester. Geeignet für eine Vielzahl von Verwendungsmöglichkeiten, insbesondere für Karosserie-Zugarbeiten. Extreme Flexibilität, leichtes Gewicht sowie hohe Belastbarkeit und Sicherheit in der Anwendung machen sie zu einem unentbehrlichen Arbeitsgerät. Die Klemmenaufnahmen der Gurte passen für alle von OMCN hergestellten Haken und Ketten.

CATENE E GANCI IN ACCIAIO LEGATO AD ELEVATA RESISTENZA, BONIFICATE, COLLAUDATE, CROMATE

CHROMED, TESTED AND TEMPERED CHAINS AND HOOKS IN HIGH RESISTANCE ALLOY STEEL

CHAÎNES ET CROCHETS EN ACIER ALLIE HAUTE RESISTANCE, TREMPÉES, TESTÉES, CHROMÉES

VERCHROMTE, GEHÄRTETE UND GEPRÜFTE KETTEN UND HAKEN AUS HOCHFESTER STAHLLEGIERUNG

CE Made in Italy 

CAVO SICURO

Safety cable
Câble de sûreté
Sicherheitskabel



ART.

mm

325

1500

325/A

2000

325/B

2500

325/C

3000



CON 1 GANCIO

with 1 hook
1 crochet
mit 1 haken

ART.

mm

300

1500

301

2000

302

2500

303

3000



CON 2 GANCI

with 2 hooks
2 crochets
mit 2 haken

ART.

mm

304

1500

305

2000

306

2500

307

3000



ART. 318
DOPPIO GANCIO PER
AGGANCIAMENTO
E ASSEMBLAGGIO CATENE

Twin hook to assemble chains
Deux crochets simples pour l'assemblage de deux chaînes
Doppelhaken zur Kettenverbindung



ART. 316
GANCIO CON ATTACCO
A FORCELLA

Hook with fork coupling
Crochet simple avec axe à goupille en acier
Haken



ART. 323
ACCORCIATORE
E CONGIUNTORE DI CATENA

Chain joiner and shortener
Double oeillet pour attache rapide de deux chaînes
Kettenverkürzer und Verbindungsglied