



YAK



SOLLEVATORI A CARRELLO TROLLEY JACKS

Ampia gamma composta da sollevatori idraulici manuali per vetture e mezzi pesanti e completata da sollevatori oleopneumatici specifici per i più svariati utilizzi.

A wide range which starts with manual hydraulic jacks for cars and heavy vehicles, and advances to air hydraulic jacks for many different applications.

Wissekerke

Nijverheidsweg 20 3251 LP Stellendam
Postbus 7 3253 ZG Ouddorp
E-mail: info@wissekerke.nl

Authorized dealer

Techniek B.V.

tel.: (0)187 - 490 290
fax: (0)187 - 490 299
www.wissekerke.nl



SOLLEVATORI OLEOPNEUMATICI A CARRELLO AIR HYDRAULIC TROLLEY JACKS

Mod.

YAK 109/C

	•
	•
	•
	•
	•
	•
	•

Sollevatore Oleopneumatico a carrello, pratico e maneggevole. Rientro automatico del braccio; le due valvole di discesa garantiscono una tenuta perfetta in ogni situazione e una velocità controllata sotto carico. La combinazione tra altezza minima, altezza massima e portata lo rendono versatile e particolarmente indicato per autovetture, camper, furgoni, autocarri medi, rimorchi e tutti i mezzi con una massa complessiva non superiore ai 12t. (13.2 ton) Ideale per officine, gommisti e carrozzerie.

Air hydraulic trolley jack, practical and easy to handle. The arm moves back automatically; the two descent valves guarantee perfect holding in all situations and controlled speed under load. Thanks to minimum height, maximum height and capacity these jacks are flexible and particularly suitable for cars, campers, vans, medium sized lorries, trailers and all vehicles weighing no more than 12t. (13.2 ton) Ideal for workshops, tyre repairers and bodywork shops.

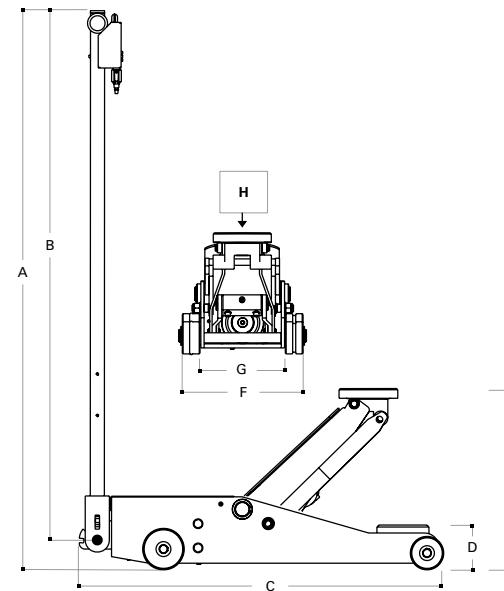

YAK 109/C



	YAK 109/C
Portata Capacity	5 t 5.5 ton
Peso netto Net weight	75kg 165 lb
Pressione di alimentazione Working air pressure	8-10 bar 116-145 psi
Consumo d'aria Air waste	400 nL/min
A	1400 mm 55.12 in
B	1310 mm 51.57 in
C	890 mm 35.04 in
D	90 mm 3.54 in
E	500 mm 16.69 in
F	320 mm 12.6 in
G	208 mm 8.19 in
H	5 t 5.5 ton