



Wissekerke

Techniek B.V.

Nijverheidsweg 20 3251 LP Stellendam tel.: (0)187 - 490 290
Postbus 7 3253 ZG Ouddorp fax: (0)187 - 490 299
E-mail: info@wissekerke.nl www.wissekerke.nl

Authorized dealer

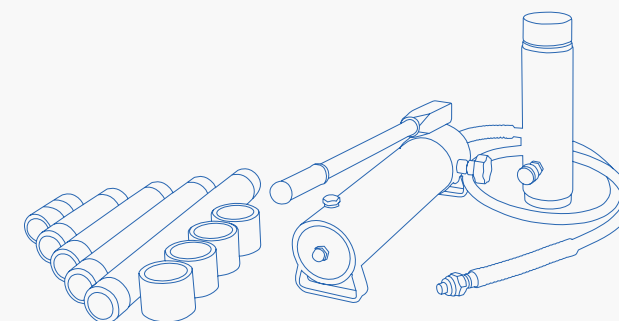

MARTINETTI IDRAULICI PER CARROZZERIA

HYDRAULIC JACKS FOR CAR-BODY SHOP
VERINS HYDRAULIQUES POUR CARROSSERIE
HYDRAULISCHE RICHTSÄTZE FÜR DEN KAROSSERIEBAU

Made in Italy 

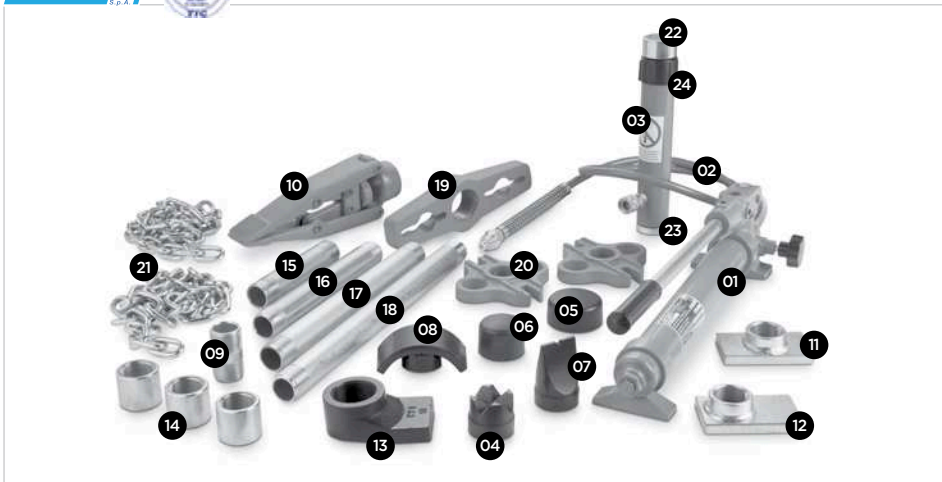

TITANIK LINE

MARTINETTI IDRAULICI PER CARROZZERIA

HYDRAULIC JACKS FOR CAR-BODY SHOP

VERINS HYDRAULIQUES POUR CARROSSERIE

HYDRAULISCHE RICHTSÄTZE FÜR DEN KAROSSERIEBAU

ART. 101 • 102 • 102 EXPORT

01 Pompa a mano • Hand-pump • Pompe manuelle • Handpumpe.

02 Tubo gomma mt. 1,8 • Fitting hose mt. 1,8 • Tuyau mt. 1,8 • Rohr auf Gummi mt. 1,8.

03 Pistone con accessori 22/23/24 • Piston with accessories 22/23/24 • Verin avec accessoires 22/23/24 • Zylinder mit Zubehör 22/23/24

04 Punzone a W a 4 punte • W-punch with 4 points • Poinçon à W à quatre pointes • Prismenaufsatz

05 Testa elastica grande da avvitare al pistone • Big elastic head to screw on piston • Grande tête caoutchouc à visser au vérin • Große Gummikappe f. Kolben.

06 Testa elastica piccola da avvitare al pistone • Little elastic head to screw on piston • Petite tête caoutchouc à visser au vérin • Kleine Gummikappe f. Kolben.

07 Punzone a cuneo • Wedge-shaped punch • Poinçon à coin • Keilaufsatz.

08 Piastra concava • Concave plate • Plaque concave • Gebogene Aufsatzdruckplatte.

09 Niplo da applicare al cilindro • Nipple to fit to cylinder • Nipple à appliquer au cylindre • Zylinderzwischenstück

10 Pinza per apertura, capacità 1 Ton • Pliers to open mudguards, capacity 1 Ton. • Main écarteuse, capacité 1 Ton. • Kotflügelspreizer, Kapazität 1 Ton.

11 Base d'appoggio da applicare al pistone • Supporting base to fit to piston • Plaque d'extension à appliquer au vérin • Basisplatte am Kolben anzubringen.

12 Piastra di estensione da applicare al pistone • Extension plate to fit to piston • Plaque d'extension à appliquer au vérin • Druckplatte, am Kolben anzubringen.

13 Piastra di estensione da applicare al cilindro • Extension plate to fit to cylinder • Plaque d'extension à appliquer au cylindre • Druckplatte, am Zylinder anzubringen.

14 N. 3 raccordi per prolunghe • N. 3 extension pipe fittings • N. 3 raccords pour rallonges • N. 3 Verlängerungsmuffen.

15 Tubo prolunga lunghezza 200 mm. • 200 mm. extension pipe • Rallonge 200 mm. • Verlängerungsrohr 200 mm.

16 Tubo prolunga lunghezza 300 mm. • 300 mm. extension pipe • Rallonge 300 mm. • Verlängerungsrohr 300 mm.

17 Tubo prolunga lunghezza 400 mm. • 400 mm. extension pipe • Rallonge 400 mm. • Verlängerungsrohr 400 mm.

18 Tubo prolunga lunghezza 500 mm. • 500 mm. extension pipe • Rallonge 500 mm. • Verlängerungsrohr 500 mm.

19 Piastra per catene da applicare al cilindro dalla parte del pistone • Plate for chains to fit to cylinder at the piston side • Plaque pour chaînes à appliquer au cylindre du côté du vérin • Spannplatte mit 2 Ketten kolbenseitig am Zylinder anzubringen.

20 N. 2 piastre per trazione e avvicinamento • N. 2 traction and approach plates • N. 2 plaques pour traction et approche • N. 2 Stk. Zug + Druckplatten.

21 N. 2 catene • N. 2 chains • N. 2 chaînes • N. 2 Ketten.

22 Tappo terminale da applicare al pistone • Terminal cap to fit to piston • Bouchon terminal à appliquer au vérin • Verschlusskappe f. Kolben.

23 Tappo terminale da applicare al cilindro • Terminal cap to fit to cylinder • Bouchon d'embout de verin • Verschlusskappe f. Zylinder.

24 Anello protezione filetto cilindro • Protection ring of cylinder thread • Bague de protection du filet du cylindre • Schutzring für Zylindergewinde.

**12
TON**



ART. 101



ART. 102



ART. 102/EXPORT

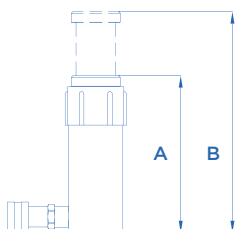

ART.	A mm	B mm
101	320	480
102	320	480
102 EXPORT	320	480

ACCESSORI EXTRA DOTAZIONE

EXTRA EQUIPMENT • ACCESSOIRES EN OPTION • EXTRA ZUBEHÖR



**ART. CM
CASSETTA IN METALLO**

Metal box • Boîte en métal
• Blechkiste



**ART. CPT
CARRELLO A DUE PIANI**

Two-shelf trolley • Chariot à deux étage
• Wagen mit zwei Ablageflächen

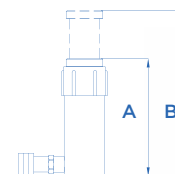

**ART. 108
PISTONE CORTO**

Short piston • Vérin court
• Kleiner Zylinder

TON	A mm	B mm
12	150	230

**ART. 357
POMPA IDROPNEUMATICA
COMPLETA DI TUBO IN GOMMA
CON ATTACCO RAPIDO**

Pneumohydraulic pump complete with rapid fitting hose
Pompe hypodermique avec tuyau raccord rapide
Pneumohydraulische pumpe mit Anschlußschlauch mit Schnellkupplung



**5
TON**



ART. 105



ART. 105/A

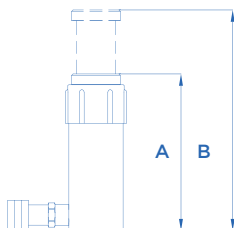

ART.	A mm	B mm
105	265	380
105/A	265	380

ACCESSORI EXTRA DOTAZIONE

EXTRA EQUIPMENT • ACCESSOIRES EN OPTION • EXTRA ZUBEHÖR



**ART. CPT
CARRELLO
A DUE PIANI**

Two-shelf trolley
Chariot à deux étage
Wagen mit zwei Ablageflächen

**ART. 357
POMPA IDROPNEUMATICA
COMPLETA DI TUBO IN GOMMA
CON ATTACCO RAPIDO**

Pneumohydraulic pump complete
with rapid fitting hose
Pompe hydropneumatique avec
tuyau raccord rapide
Pneumohydraulische pumpe
mit Anschlußschlauch mit Schnellkupplung



ART. 105



ART. 105/A



ART. 105 • 105/A

01 Pompa • Pump • Pompe • Pumpe.

02 Pistone • Piston • Verin • Zylinder.

03 Tubo gomma mt. 1,8 • Fitting hose mt. 1,8 • Tuyau mt. 1,8 • Rohr auf Gummi mt. 1,8.

04 Pinza apertura parafanghi, capacità 1 Ton. • Pliers to open mudguards, capacity 1 Ton.
• Pince ouverture pare-boues, capacité 1 Ton. • Kotflügelspreizer, Kapazität 1 Ton.

04/A Pinza apertura parafanghi, capacità 1 Ton. • Pliers to open mudguards, capacity 1 Ton.
Pince ouverture pare-boues, capacité 1 Ton. • Kotflügelspreizer, Kapazität 1 Ton.

05 Base d'appoggio • Supporting base • Base d'appui • Stützplatte.

06 Piastra di estensione da applicare al pistone • Extension plate to fit to the piston
• Plaque d'extension à appliquer au vérin • Zugplatte, wird am Kolben angebracht.

07 Punzone a cuneo • Wedge-shaped punch • Poinçon à coin • Keilaufsatz.

08 Testa elastica • Elastic head • Tête caoutchouc • Prismenaufsatz.

09 Piastra di estensione da applicare al cilindro • Extension plate to fit to the cylinder
• Plaque d'extension à joindre au cylindre • Keilaufsatz, wird am Kolben angebracht.

10 Punzone a W • W punch • Poinçon à W • Zugplatte, wird am Zylinder angebracht.

11 Tubo prolunga 50 mm. • 50 mm. extension pipe • Rallonge 50 mm. • Verlängerungsrohr 50 mm.

12 Tubo prolunga 100 mm. • 100 mm. extension pipe • Rallonge 100 mm. • Verlängerungsrohr 100 mm.

13 Tubo prolunga 200 mm. • 200 mm. extension pipe • Rallonge 200 mm. • Verlängerungsrohr 200 mm.

14 Tubo prolunga 300 mm. • 300 mm. extension pipe • Rallonge 300 mm. • Verlängerungsrohr 300 mm.

14/A Tubo prolunga 400 mm. • 400 mm. extension pipe • Rallonge 400 mm. • Verlängerungsrohr 400 mm.

15 Tubo prolunga 500 mm. • 500 mm. extension pipe • Rallonge 500 mm. • Verlängerungsrohr 500 mm.

16/A Raccordi per prolunghe • Extension pipe fittings • Raccords pour rallonges • Zubehörteile für Verlängerungsrohre.

**12
TON**



ART. 353



ART. 354

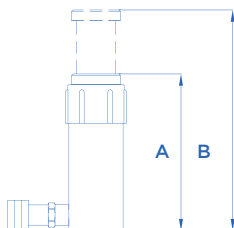

ART.	A mm	B mm
353	360	520
354	360	520

ACCESSORI EXTRA DOTAZIONE

EXTRA EQUIPMENT • ACCESSOIRES EN OPTION • EXTRA ZUBEHÖR



**ART. CPT
CARRELLO
A DUE PIANI**

Two-shelf trolley.
Chariot à deux étage.
Wagen mit zwei Ablageflächen.

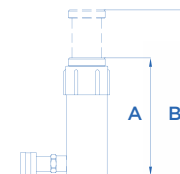

**ART. 108
PISTONE CORTO**

Short piston • Vérin court
• Kleiner Zylinder

TON	A mm	B mm
12	150	230

**ART. 357
POMPA IDROPNEUMATICA
COMPLETA DI TUBO IN GOMMA
CON ATTACCO RAPIDO**

Pneumohydraulic pump complete
with rapid fitting hose
Pompe hydropneumatique avec
tuyau raccord rapide
Pneumohydraulische Pumpe
mit Anschlußschlauch mit Schnellkupplung



ART. 353

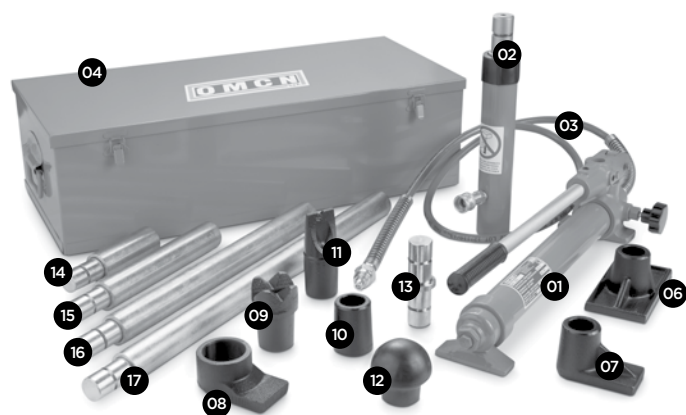

ART. 354

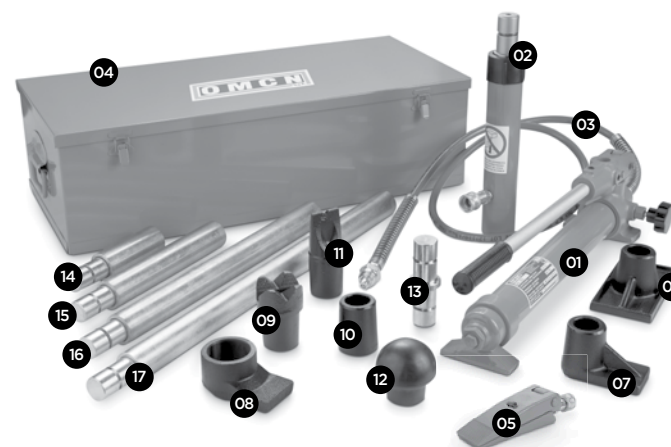

ART. 353 • 354

01 Pompa • Pump • Pompe • Pumpe.

02 Pistone • Piston • Verin • Zylinder.

03 Tubo gomma mt. 1,8 • Fitting hose mt. 1,8 • Tuyau mt. 1,8 • Rohr auf Gummi mt. 1,8.

04 Cassetta metallica • Metal box • Coffret métallique • Rückschlagventil und Blechkiste.

05 Pinza apertura parafanghi, capacità 1 Ton. • Pliers to open mudguards, capacity 1 Ton.
• Pince ouverture pare-boues, capacité 1 Ton. • Kotflügelspreizer, Kapazität 1 Ton.

06 Base d'appoggio • Supporting base • Base d'appui • Stützplatte.

07 Piastra di estensione da applicare al pistone • Extension plate to fit to the piston
• Plaque d'extension à appliquer au vérin • Zugplatte, wird am Kolben angebracht.

08 Piastra di estensione da applicare al cilindro • Extension plate to fit to the cylinder
• Plaque d'extension à joindre au cylindre • Keilaufsatz, wird am Kolben angebracht.

09 Punzone a W • W punch • Poinçon à W • Zugplatte, wird am Zylinder angebracht.

10 Punzone zigrinato • Knurled punch • Poinçon moleté • Gerändelte Stempelplatte.

11 Punzone a cuneo • Wedge-shaped punch • Poinçon à coin • Keilaufsatz.

12 Testa elastica • Elastic head • Tête caoutchouc • Prismenaufsatz.

13 Raccordo doppio maschio • Double male fitting • Raccord double mâle • Adapter.

14 Tubo prolunga 120 mm. • 120 mm. extension pipe • Rallonge 120 mm. • Verlängerungsrohr 120 mm.

15 Tubo prolunga 250 mm. • 250 mm. extension pipe - Rallonge 250 mm. • Verlängerungsrohr 250 mm.

16 Tubo prolunga 460 mm. • 460 mm. extension pipe • Rallonge 460 mm. • Verlängerungsrohr 460 mm.

17 Tubo prolunga 630 mm. • 630 mm. extension pipe • Rallonge 630 mm. • Verlängerungsrohr 630 mm.

**6
TON**



ART. 355



ART. 356

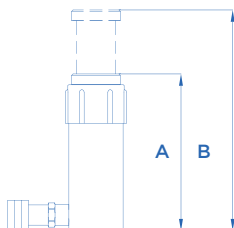

ART.	A mm	B mm
355	290	410
356	290	410

ACCESSORI EXTRA DOTAZIONE

EXTRA EQUIPMENT • ACCESSOIRES EN OPTION • EXTRA ZUBEHÖR



**ART. CPT
CARRELLO
A DUE PIANI**

Two-shelf trolley
Chariot à deux étage
Wagen mit zwei Ablageflächen

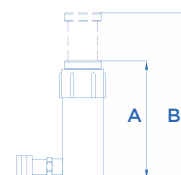

**ART. 108/A
PISTONE CORTO**

Short piston • Vérin court
• Kleiner Zylinder

TON	A mm	B mm
6	150	230

**ART. 357
POMPA IDROPNEUMATICA
COMPLETA DI TUBO IN GOMMA
CON ATTACCO RAPIDO**

Pneumohydraulic pump complete
with rapid fitting hose
Pompe hydro-pneumatique avec
tuyau raccord rapide
Pneumohydraulische pumpe
mit Anschlußschlauch mit Schnellkupplung



ART. 355

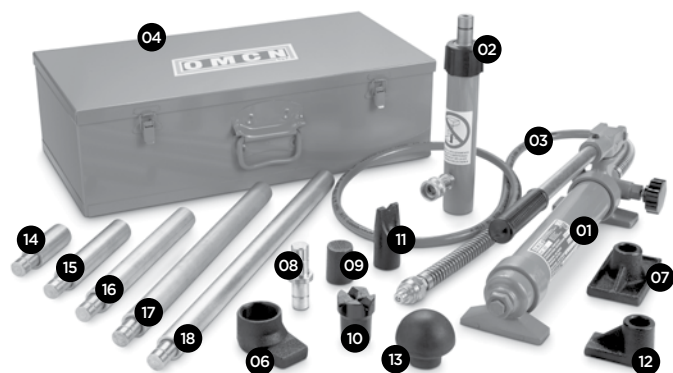

ART. 356

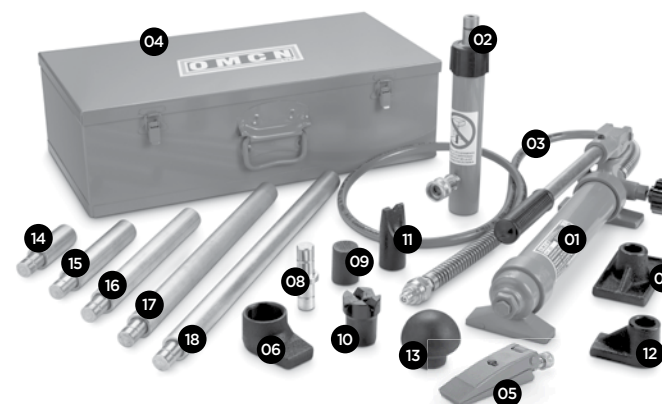

ART. 355 • 356

01 Pompa • Pump • Pompe • Pumpe.

02 Pistone • Piston • Verin • Zylinder.

03 Tubo gomma mt. 1,8 • Fitting hose mt. 1,8 • Tuyau mt. 1,8 • Rohr auf Gummi mt. 1,8.

04 Cassetta metallica • Metal box • Coffret métallique • Rückschlagventil und Blechkiste.

05 Pinza apertura parafanghi, capacità 1 Ton. • Pliers to open mudguards, capacity 1 Ton. Pince ouverture pare-boues, capacité 1 Ton. • Kotflügelspreizer, Kapazität 1 Ton.

06 Piastra di estensione da applicare al cilindro • Extension plate to fit to the cylinder Plaque d'extension à joindre au cylindre • Keilaufsatz, wird am Kolben angebracht.

07 Base d'appoggio • Supporting base • Base d'appui • Stützplatte.

08 Raccordo doppio maschio • Double male fitting • Raccord double mâle • Adapter.

09 Punzone zigrinato • Knurled punch • Poinçon moleté • Gerändelte Stempelplatte.

10 Punzone a W • W punch • Poinçon à W • Zugplatte, wird am Zylinder angebracht.

11 Punzone a cuneo • Wedge-shaped punch • Poinçon à coin • Gummikappe.

12 Piastra di estensione da applicare al pistone • Extension plate to fit to the piston Plaque d'extension à appliquer au vérin • Zugplatte, wird am Kolben angebracht.

13 Testa elastica • Elastic head • Tête caoutchouc • Prismenaufsatz.

14 Tubo prolunga 75 mm. • 75 mm. extension pipe • Rallonge 75 mm. • Verlängerungsrohr 75 mm.

15 Tubo prolunga 150 mm. • 150 mm. extension pipe • Rallonge 150 mm. • Verlängerungsrohr 150 mm.

16 Tubo prolunga 250 mm. • 250 mm. extension pipe • Rallonge 250 mm. • Verlängerungsrohr 250 mm.

17 Tubo prolunga 400 mm. • 400 mm. extension pipe • Rallonge 400 mm. • Verlängerungsrohr 400 mm.

18 Tubo prolunga 500 mm. • 500 mm. extension pipe • Rallonge 500 mm. • Verlängerungsrohr 500 mm.

HEAVY DUTY



ART. 100

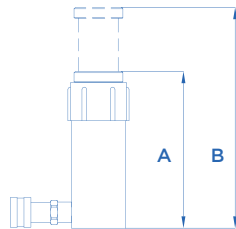

ART.	TON	A mm	B mm
100	20	310	440
100/A	30	310	440



ART. 100/C

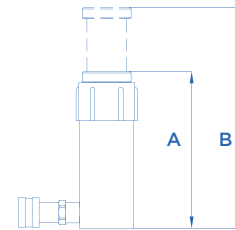

ART.	TON	A mm	B mm
100/B	50	330	465
100/C	80	330	470
100/D	120	320	460

ART. 100 • 100/A • 100/B • 100/C • 100/D

01 Pompa • Pump • Pompe • Pumpe.

02 Tubo gomma mt. 1,8 • Fitting hose mt. 1,8 • Tuyau mt. 1,8 • Rohr auf Gummi mt. 1,8.

03 Pistone • Piston • Verin • Zylinder.

04 Tubo prolunga 100 mm. • 100 mm. extension pipe • Rallonge 100 mm. • Verlängerungsrohr 100 mm.

05 Tubo prolunga 200 mm. • 200 mm. extension pipe • Rallonge 200 mm. • Verlängerungsrohr 200 mm.

06 Tubo prolunga 300 mm. • 300 mm. extension pipe • Rallonge 300 mm. • Verlängerungsrohr 300 mm.

07 Tubo prolunga 400 mm. • 400 mm. extension pipe • Rallonge 400 mm. • Verlängerungsrohr 400 mm.

08 Tubo prolunga 500 mm. • 500 mm. extension pipe • Rallonge 500 mm. • Verlängerungsrohr 500 mm.

09 Raccordi per prolunghe • Extension pipe fittings • Raccords pour rallonges • Zubehörteile für Verlängerungsrohre.

10 Tappi terminali • Terminal caps • Bouchons terminaux • Verschlusskappen.





ART. 350/A
POMPA IDRAULICA MANUALE COMPLETA DI TUBO IN GOMMA CON ATTACCO RAPIDO

Hydraulic pump complete with rapid fitting hose
 Pompe hydraulique avec tuyau à raccord rapide
 Hydraulische pompe mit Anschlußschlauch mit Schnellkupplung



ART. 357
POMPA IDROPNEUMATICA COMPLETA DI TUBO IN GOMMA CON ATTACCO RAPIDO

Pneumohydraulic pump complete with rapid fitting hose
 Pompe hydropneumatique avec tuyau raccord rapide
 Pneumohydraulische pompe mit Anschlußschlauch mit Schnellkupplung

PISTONI SPINGENTI

PUSHING CYLINDERS
 VÉRINS POUSSEURS
 DRUCKZYLINDERN

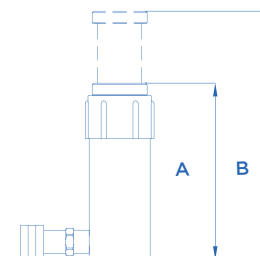

ART.	TON	A mm	B mm
108	12	150	230
108/A	6	150	230
350/C	12	400	630

ART. 108
PISTONE CORTO

Short piston
 Vérin court
 Kleiner Zylinder

12
TON



ART. 108/A
PISTONE CORTO

Short piston
 Vérin court
 Kleiner Zylinder

6
TON



ART. 350/C

12
TON



OPTIONAL



ART. 324
ATTACCO SPECIALE PER BANCHI DI SQUADRATURA

Special swivel attachment
 Attache spéciale pour marbres de redresseage
 Verbindungsgabel für Richtbänke



PISTONI TIRANTI

PULLING CYLINDERS
VÉRINS TIREURS
ZUGZYLINDERN



6
TON

ART. 350/D



6
TON

ART. 351



ART.	TON	A mm	B mm
350/D	6	530	350
351	6	770	470

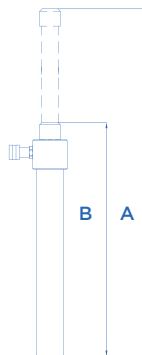

OPTIONAL

ART. 321 GANCIO A DOPPIA PRESA (MANINA) CON ATTACCO FILETTATO

Claw hook with threaded connection.

Crochet à double prise articulé sur raccord fileté femelle.

Klaue mit Gewinde.



OPTIONAL

ART. 322 OCCHIELLO PER AGGANCIAMENTO CATENA AL PISTONE

Hook for joining closed chain to power ram.

Oeillet pour attache rapide de chaîne.

Öse zum Anhängen der Kette an den Kolben.

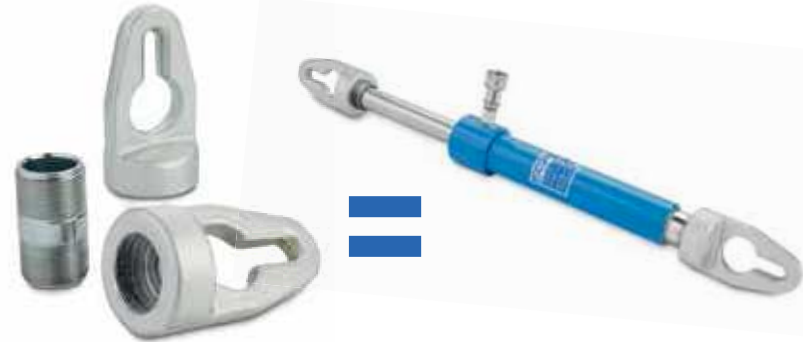

OPTIONAL

ART. 350/E

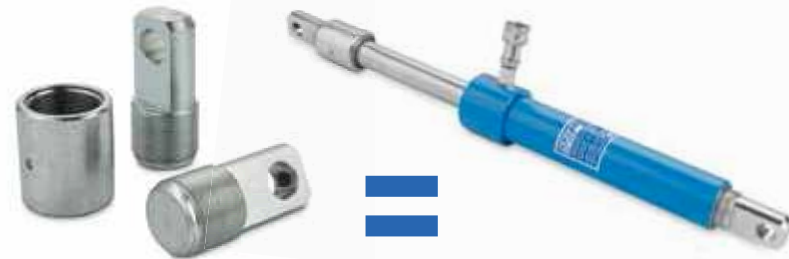

KIT

**ART. 106/A
PISTONE TIRANTE**

Pulling piston.
Vérin tirant.
Zugzylinder.

**6
TON**



Completo di attacco rapido, n° 2 raccordi filettati con naselli snodati, n° 2 catene da mt. 1,5 complete di gancio.

Complete with rapid coupling, no 2 threaded couplings with jointed nips and 2 1,5 mt. chains complete with hook.

Avec raccord rapide, 2 raccords filetés avec déclics dénoués et 2 chaînes de 1,5 mt. avec crochet.

Komplett mit Schnellkupplung, 2 Kupplungen mit Gewinde und 2 1,5 mt. langen Ketten mit Haken.

ART.

TON

A
mm

B
mm

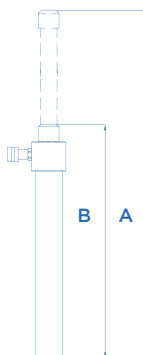

106/A

6

610

395

106/B

4

460

310

KIT

**ART. 106/B
PISTONE TIRANTE**

Pulling piston.
Vérin tirant.
Zugzylinder.

**4
TON**



Completo di attacco rapido e di due supporti con gancio nelle parti terminali.

Complete with rapid coupling and with two supports equipped with hook in terminal parts.

Livré avec raccord rapide et 2 supports avec crochets aux extrémités.

Komplett mit Schnellkupplung und 2 Gewindekupplungen mit Haken.



OPTIONAL

ART. 106/B1



N° 2 catene filo Ø 7 in acciaio legato ad elevata resistenza, bonificate, collaudate e cromate, da mt. 1,5 cad. complete di gancio.

No. 2 chains wire Ø 7 in high resistance alloy steel, tempered, tested and chromated of mt. 1,5 each one, complete with hook.

2 chaînes fil Ø 7 en acier trempé et chromé. Longueur 1,5 mt. chacune avec crochet.

2 Ketten Ø 7 aus einer hochwiderstandsfähigen Stahllegierung; gehärtet, geprüft und verchromt, 1,5 mt. lang, komplett mit Haken.

**ART. 096
BATTITOIO A CONTRACCOLPO**

Counterblow hammer.
Appareil pour le coup et contrecoup.
Schlaghammer.



**ART. 096/A
BATTITOIO A CONTRACCOLPO CORREDATO DI GANCI SPECIALI ED INNESTO PER MORSETTI**

Counterblow hammer with special hooks and coupling for clamps.
Appareil pour le coup et contrecoup avec crochets spéciaux et greffe pour étaux.
Schlaghammer ausgestattet mit Spezialhaken und Klemmenaufnahme



**ART. 290
ALLARGATORE IDRAULICO A CUNEO COMPLETO DI ACCOPPIATORE RAPIDO APERTURA 85 MM. DA 1 TON**

1 Ton. hydraulic wedge spread, opening 85 mm.
Ouverture hydraulique à coin de max. 85 mm. Puissance 1 Ton. équipée d'un demi-coupleur rapide.
Hydraulischer Spreizer. Öffnung max. 85 mm. ausgestattet mit Schnellöffnung. Zugkraft 1 Ton.

NOTE
