



**Wissekerke**

Techniek B.V.

Nijverheidsweg 20 3251 LP Stellendam tel.: (0)187 - 490 290  
Postbus 7 3253 ZG Ouddorp fax: (0)187 - 490 299  
E-mail: info@wissekerke.nl www.wissekerke.nl

Authorized dealer

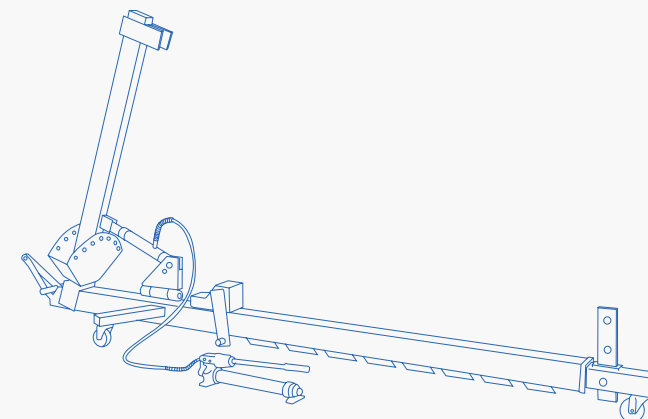

## **RADDRIZZATORI PER CARROZZERIA**

STRAIGHTENERS FOR CAR-BODY SHOP  
EQUERRES DE REDRESSAGE POUR CARROSSERIE  
KAROSSERIE-RICHTGERÄTE

Made in Italy 

**12  
TON**

**STRONG  
LINE**

# RADDRIZZATORI PER CARROZZERIA

STRAIGHTENERS FOR CAR-BODY SHOP  
EQUERRES DE REDRESSAGE POUR CARROSSERIE  
KAROSSERIE-RICHTGERÄTE

ART.	MAX mm	MIN mm	mm	KG
<b>MAJOR/R</b>	6500	3650	1750	340
<b>EXPORT</b>	4600	3150	1650	250

**ONLY**

## ART. STRONG MAJOR/R

Grazie al dispositivo di inclinazione sinistra-destra del braccio verticale, si può avere una maggiore rapidità e facilità d'impiego.

Thanks to the left and right inclination device of the vertical arm, one can get a better rapidity and facility of use.

Facilité d'emploi grâce au dispositif d'inclinaison gauche/droite du bras vertical.

Der nach rechts und links schwenkbare Vertikalarm ermöglicht eine schnelle und einfache Bedienung des Geräts.

ART. STRONG MAJOR/R



MAJOR/R	EXPORT	Accessori • Accessories • Accessoires • Einzelteile
✓	✓	<b>A/1</b> Braccio verticale sul quale scorre il morsetto di agganciamento catene • Vertical arm • Bras vertical • Vertikalarm, auf dem die Kettenklemme läuft.
✓	✓	<b>A/2</b> Braccio orizzontale sul quale scorre la staffa di ancoraggio a due posizioni alta e bassa con il sistema di bloccaggio • Horizontal arm • Bras horizontal • Horizontalarm, auf dem der Verankerungssattel mit Hoch und TiefEinstellung und (patentiertem) Fixiersystem läuft.
✓	✓	<b>A/3</b> Braccio di prolunga alla cui estremità si inserisce il piatto attacco catene • Extension arm • Bras d'extension • Verlängerungsarm, an dessen Ende der Kettenteller eingesetzt wird.
✓	✓	<b>B</b> Piastre a morsetti speciali • Special clamp plates • Plaques à étaux spéciaux • Platten mit Spezialklemmen
✓	✓	<b>C</b> Morsetti autobloccanti • Self-locking clamps, specially designed to hook the damaged part • Etaux auto-bloquants • Selbstschließende Klemmen, um die beschädigten Teile einzuheken
✓	✓	<b>D</b> Tirante con doppia piastra • Tie bar with double plate • Tirant avec plaque double • Doppelplattenzuganker
<b>3</b>	<b>2</b>	<b>E</b> Catene con ganci • Chains with hook • Chaînes avec croche • Ketten mit Haken
✓	✓	<b>F</b> Pompa idraulica con tubo flessibile e pistone • Hydraulic pump + piston + hose • Pompe hydraulique + vérin + tube flexible • Blechkasten
✓		<b>G</b> Cassetta in lamiera • Sheet box • Caisse en tôle • Vierkantröhr
✓		<b>H</b> Barra quadra • Square bar • Barre carrée • Vierkantröhr
✓	✓	<b>I</b> Barra tonda • Round bar • Barre ronde • Rundrohr
✓		<b>L</b> Barra tonda corta • Short round bar • Barre ronde courte • Kurzes Rundrohr
<b>4</b>	<b>2</b>	<b>M</b> Colonnate sostegno vettura • Car supporting stands • Chandelles d'appui pour voitures • Unterstellböcke

**NOTE**

---

---

---

---

---

---

---

---

---

---

---

---

---

---

---

---

---

---

---

---

---

---

---

---